

# Applications 2020

*Let's create efficient and appropriate workplaces!*

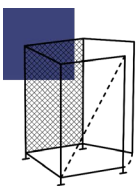

Machine frames and housings

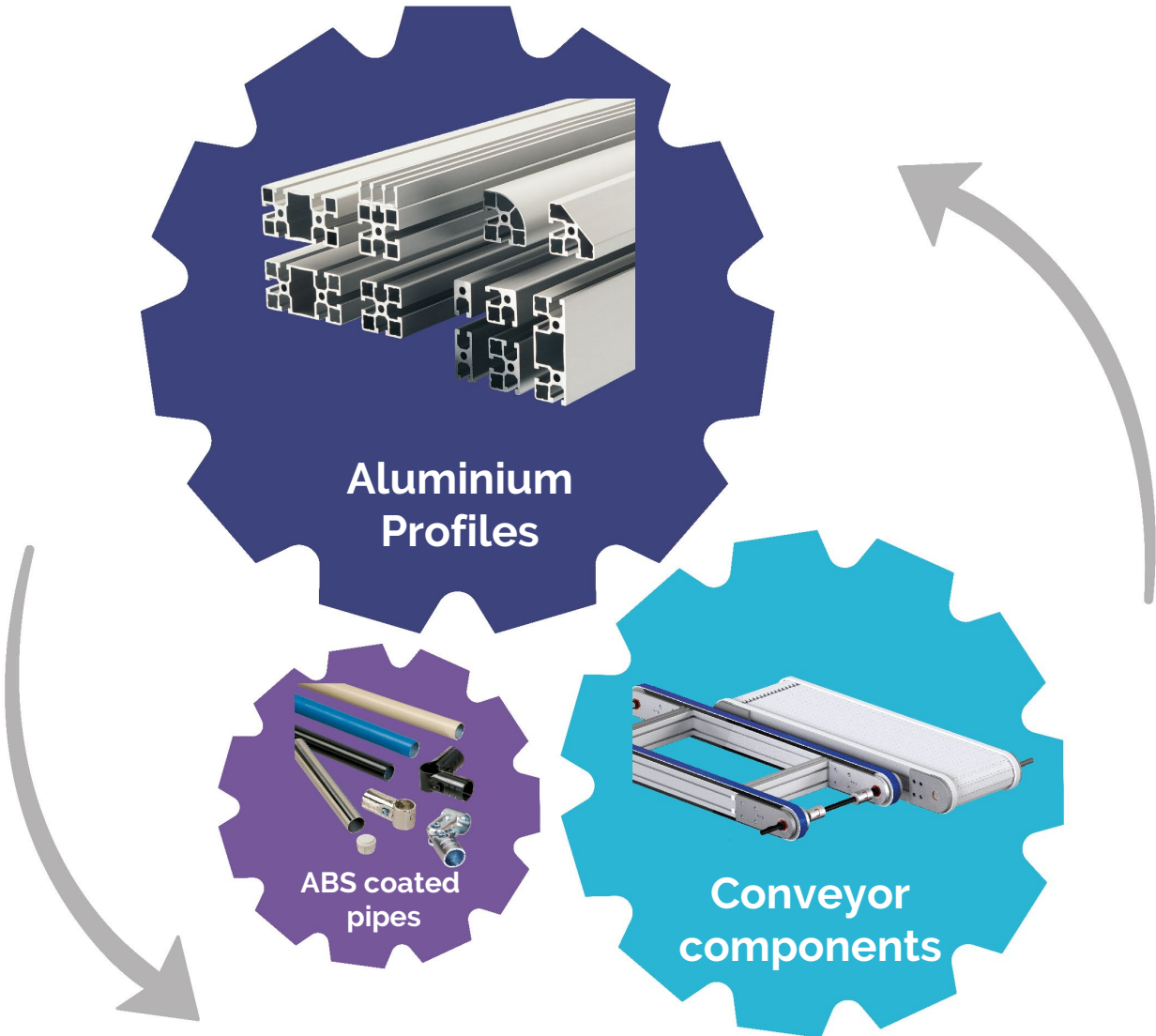
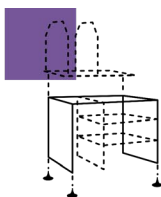

Workstations and technical furniture

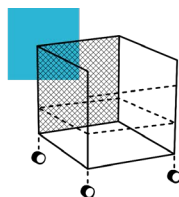

Trolleys & carts, material handling

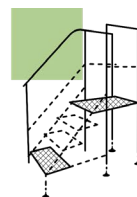

Access platforms, gangways and steps



Material flows and conveyors

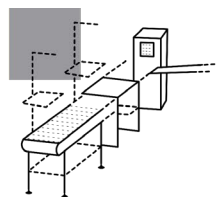

... specialized production cells and full installations



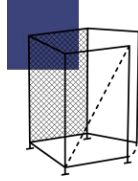

Machine frames and housings

03-18

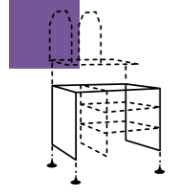

Workstations and technical furniture

19-37

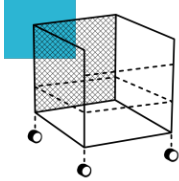

Trolleys & carts, material handling

38-51

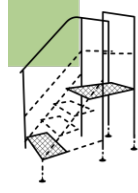

Access platforms, gangways and steps

52-54

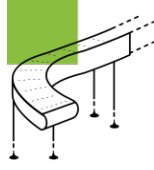

Material flows and conveyors

54-73

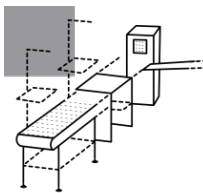

... specialized production cells and full installations

74-79

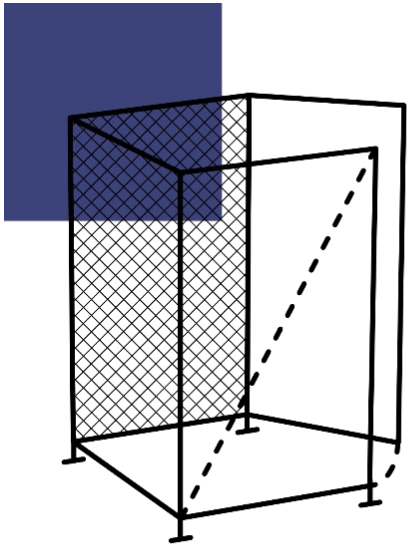

Machine frames  
and housings

PR2003249 – NORCAN  
Guarding system with sliding doors for storage area



**EC20H00219-AC**

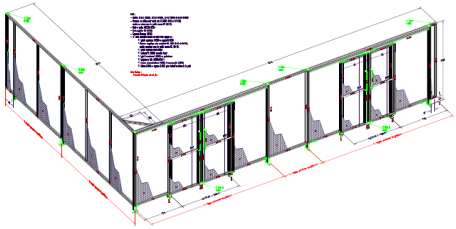

PR1912550 – Norcan GmbH  
Standard modular enclosure for area with a robotic arm

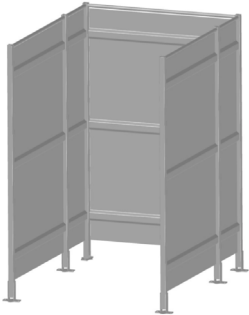

**EC19Z00135**

PR2002207 – SEP/WEC  
For laboratory



**EC20M00152**

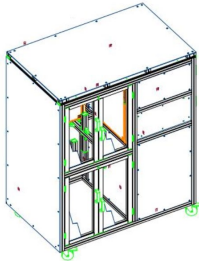

PR1911124 – PAG/VJU  
Thermal enclosure

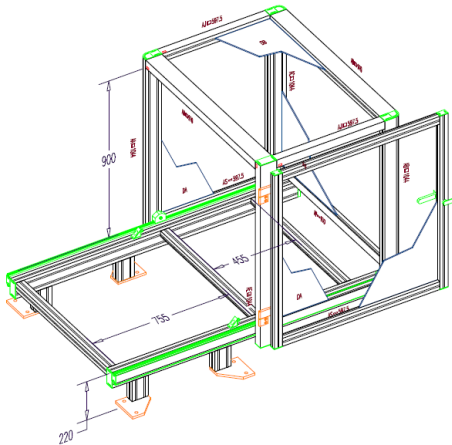

**EC20L000207**

PR2008025 – CLI/NCA

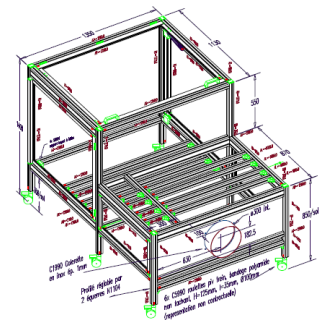

**EC20W00191**

PR2005447 – LBE  
Protective casing

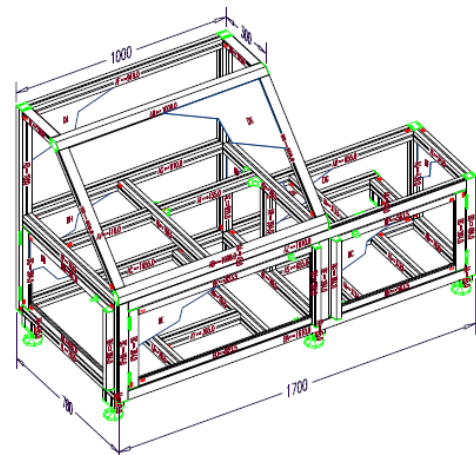

**EC20Q00130**

PR1908819 - MGR/LOM  
Support trolley for robotic arm

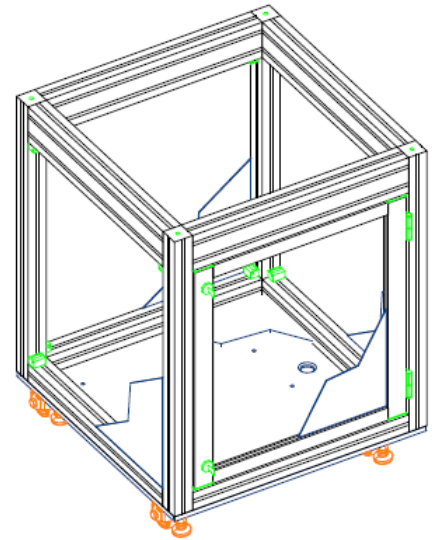

**EC20X00173**  
**EC20X00147**

N18C156 - CLI/LOM  
Self-supporting structure for robotic arm

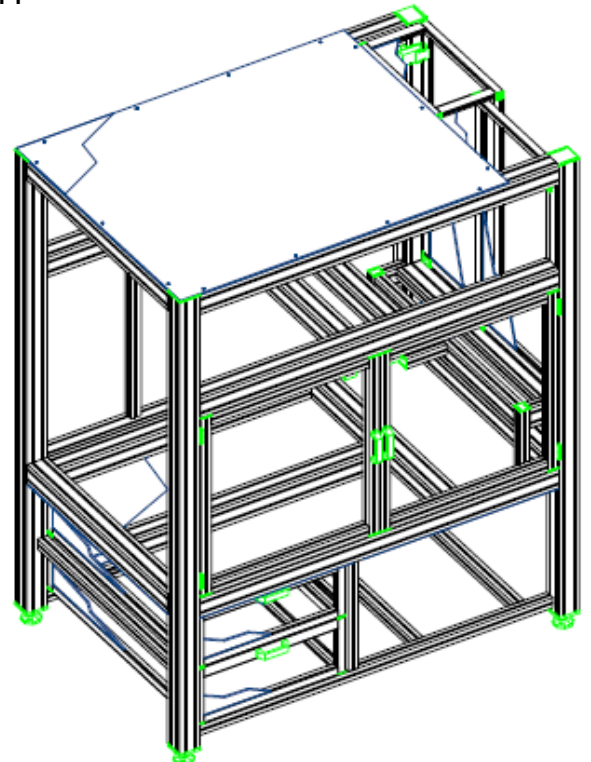
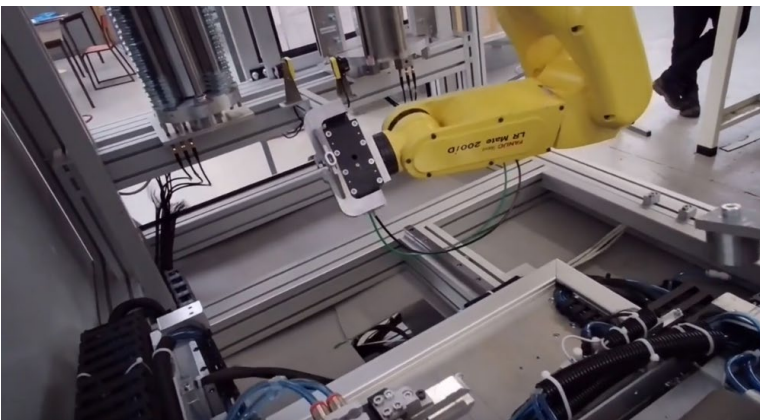

**EC18D0005**



PR1910278 – HRO/CHS  
Vertical balanced housing 1900x1300mm  
- 2 profiles 90x90

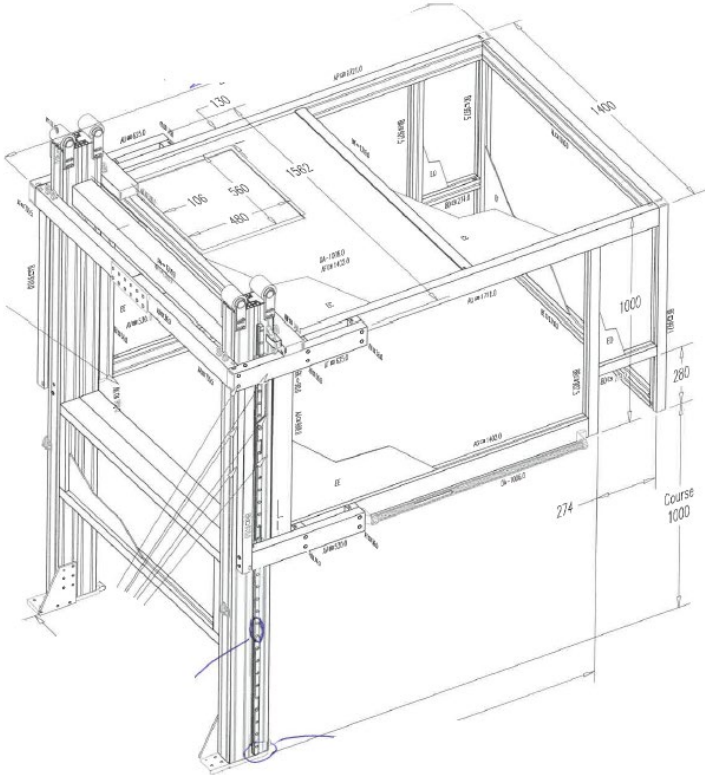
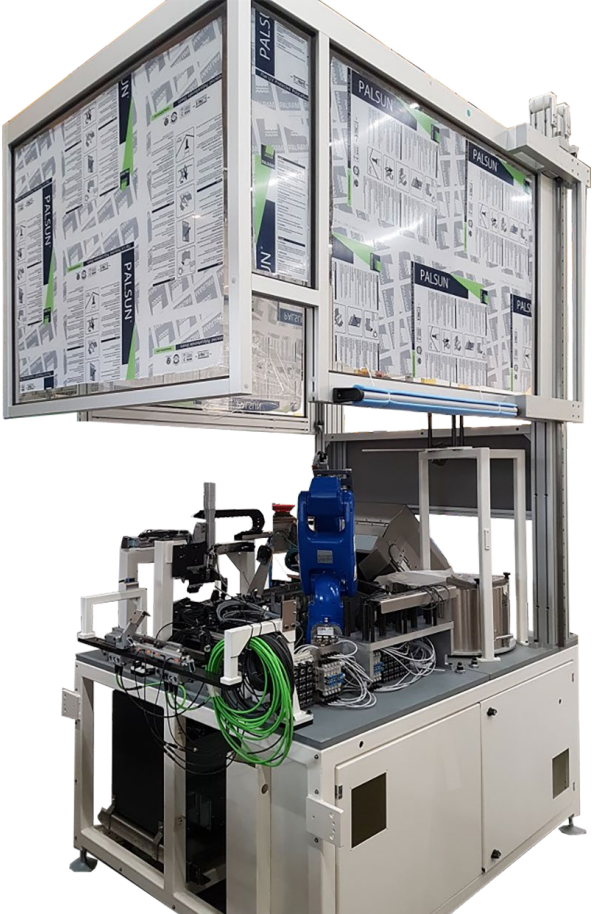

**EC18Z00212**



PR1911712 – MGR/CHS  
Frame for housing a laser engraving  
device



**EC16X00010**

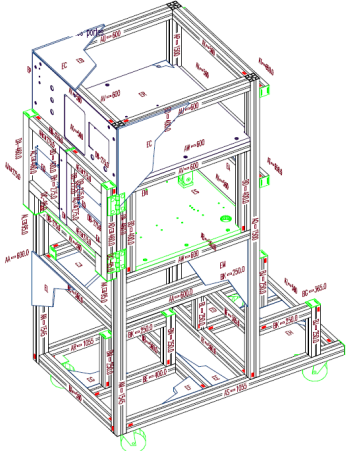

PR2007457 – HRO/PRB  
Structure

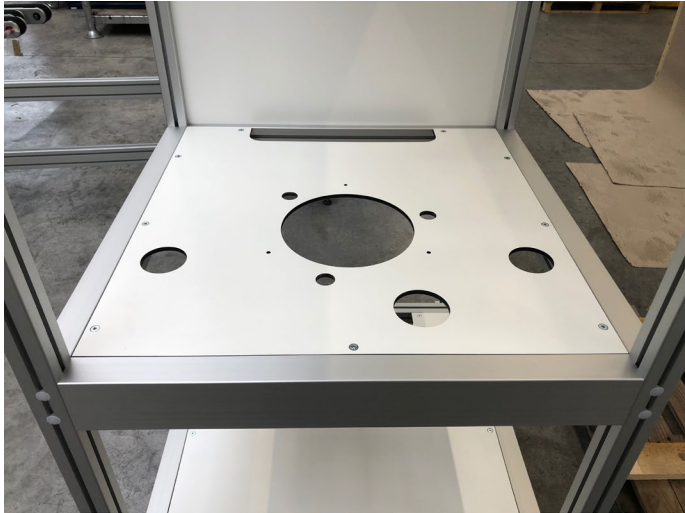

**EC20V00112**

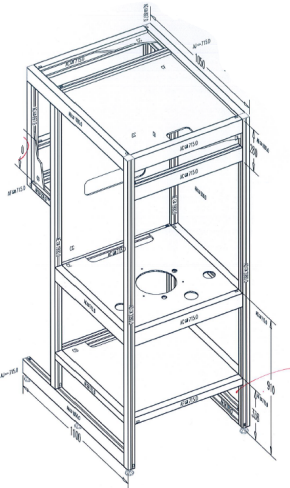

PR1910181 – SEP/VJU  
90° rotation of a cockpit with less pain

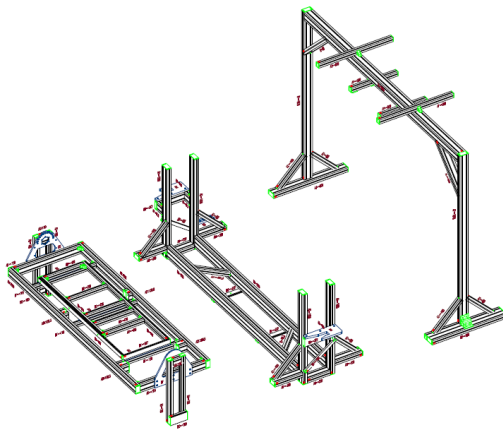
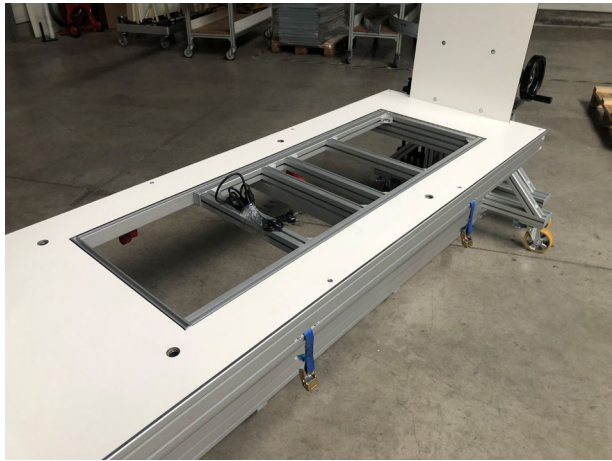

**EC19Y00353-AD**

PR1910119 – LDB/CHS  
School porch

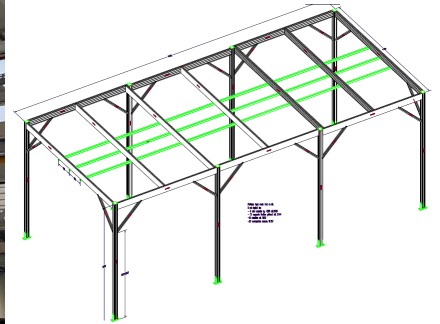

**EC19Z00144-AB**

PR1903467 – HRO/ZES  
Frame for filtering system

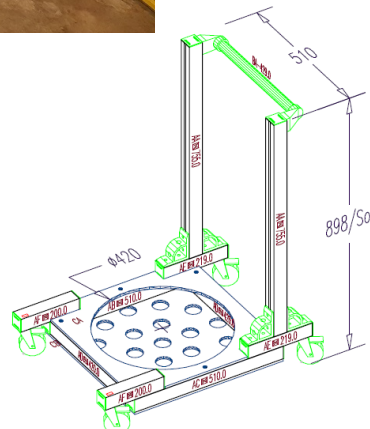
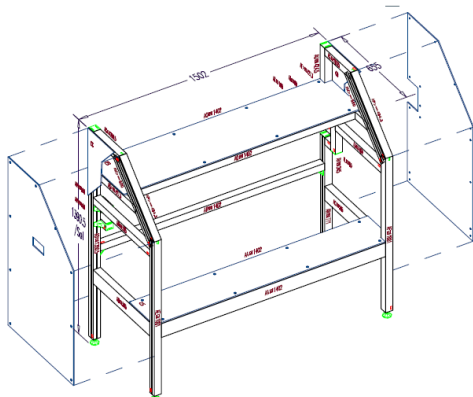

**EC19K00206-AB**  
**EC19K00208-AB**

PR2002875 – LDB/ZES  
Up and down batcher

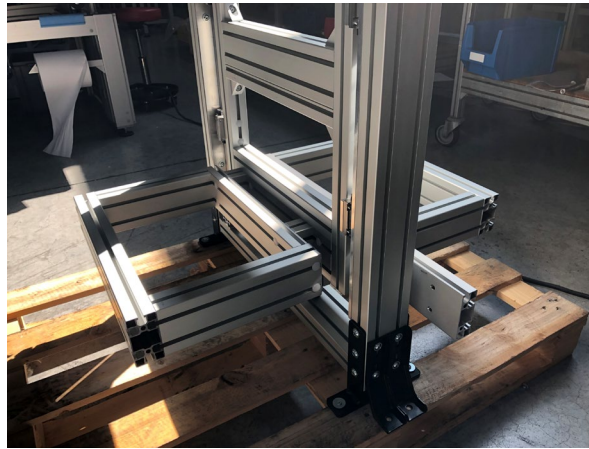

**EC18E00447**

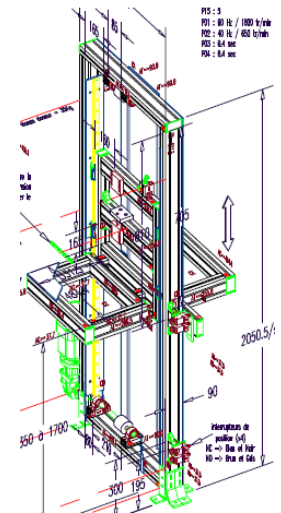

PR2004049 – Norcan Polska  
Movable separating panels for welding areas



**EC20L00105**

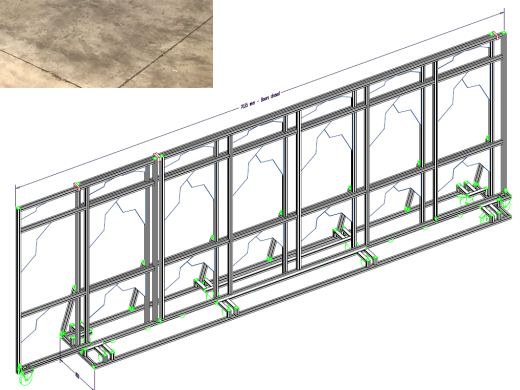

MN15977 – Norcan Hispanica  
Automatic plastic caps dispenser.  
4 cardboard boxes are placed inside the structure, The filling is sequentially carried out. Inside the chimney there is a bypass with actuators to distribute the pieces, preliminarily counted by the extruder itself.

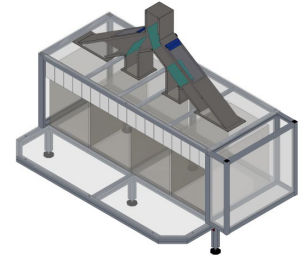
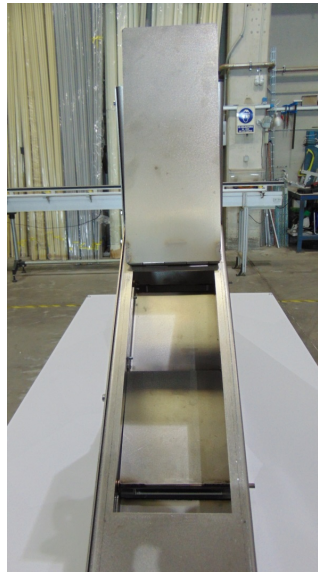

MN16433 – Norcan Hispanica  
Protective casing for the pressing of CLIPPER lighters, The structure is perfectly articulated with openings on the front to allow for a better access to the equipment.

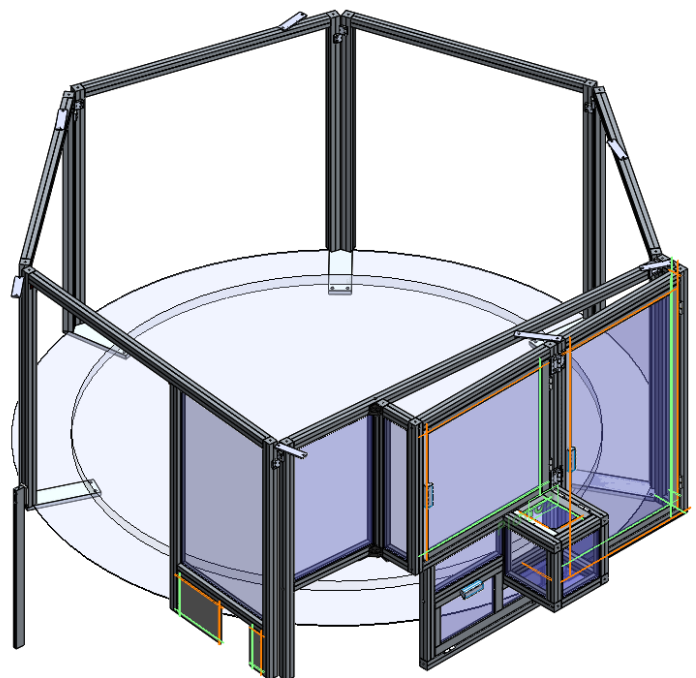

MN16561 – Hispanica  
 Completely modular taylor-made casing  
 with fast fixation for a machine  
 manufacturer

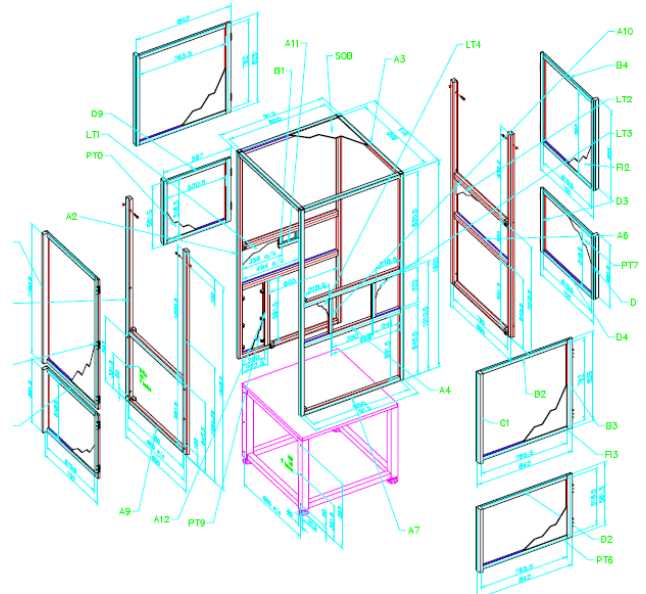

MN16751 – Norcan Hispanica - Claw with dimensions  
 2750x1820x210mm for a robotic ABB arm – Handling of  
 cardboard sheets 3400 x 2200 mm. No166 aluminium  
 profiles are used as fillers for 30 suction cups (15 per side)

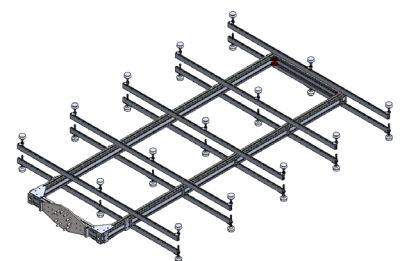
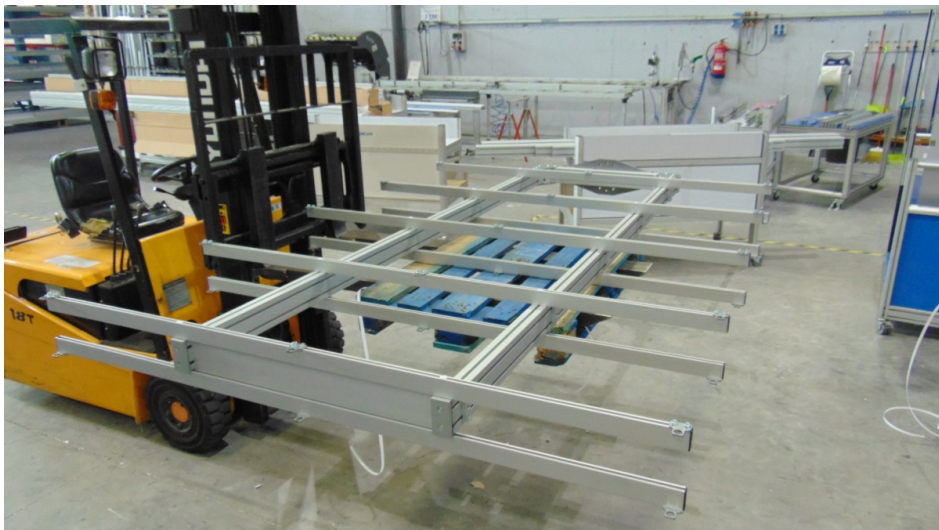

MN16739 – Norcan Hispanica  
 Casing with an ergonomical opening  
 We maximize the opening gap on the front  
 and top of the box to increase the operator's  
 control. The shock absorbers compensate for the weight and  
 trajectory of the folding door

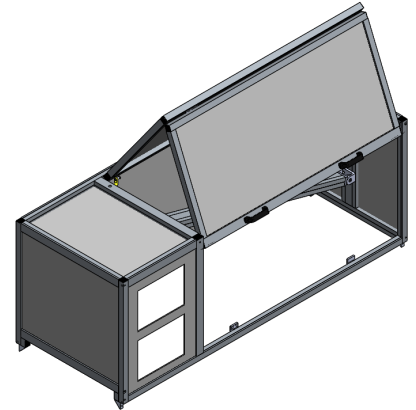

MN15993 – Norcan Hispanica- Simple structure for a laser  
 head, Table equipped with balls to convey circuit boards.  
 With closing panels in ALUCOBOND so the customer can  
 easily integrate external devices

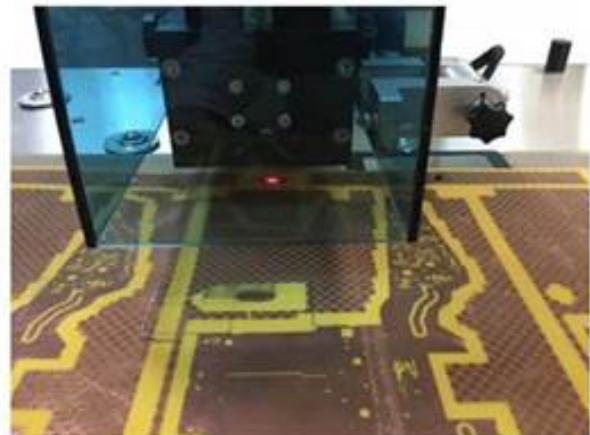
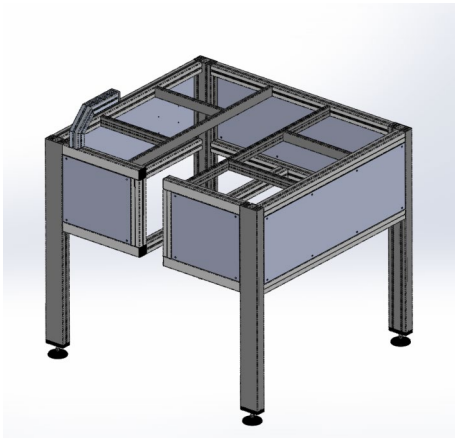



MN16654 - Norcan Hispanica  
Bench for the calibration of electronic  
measuring devices



Norcan Morocco -  
Extractor hood for vapors from glue or  
welding fumes : The suction is carried  
out through the square holes in the grid

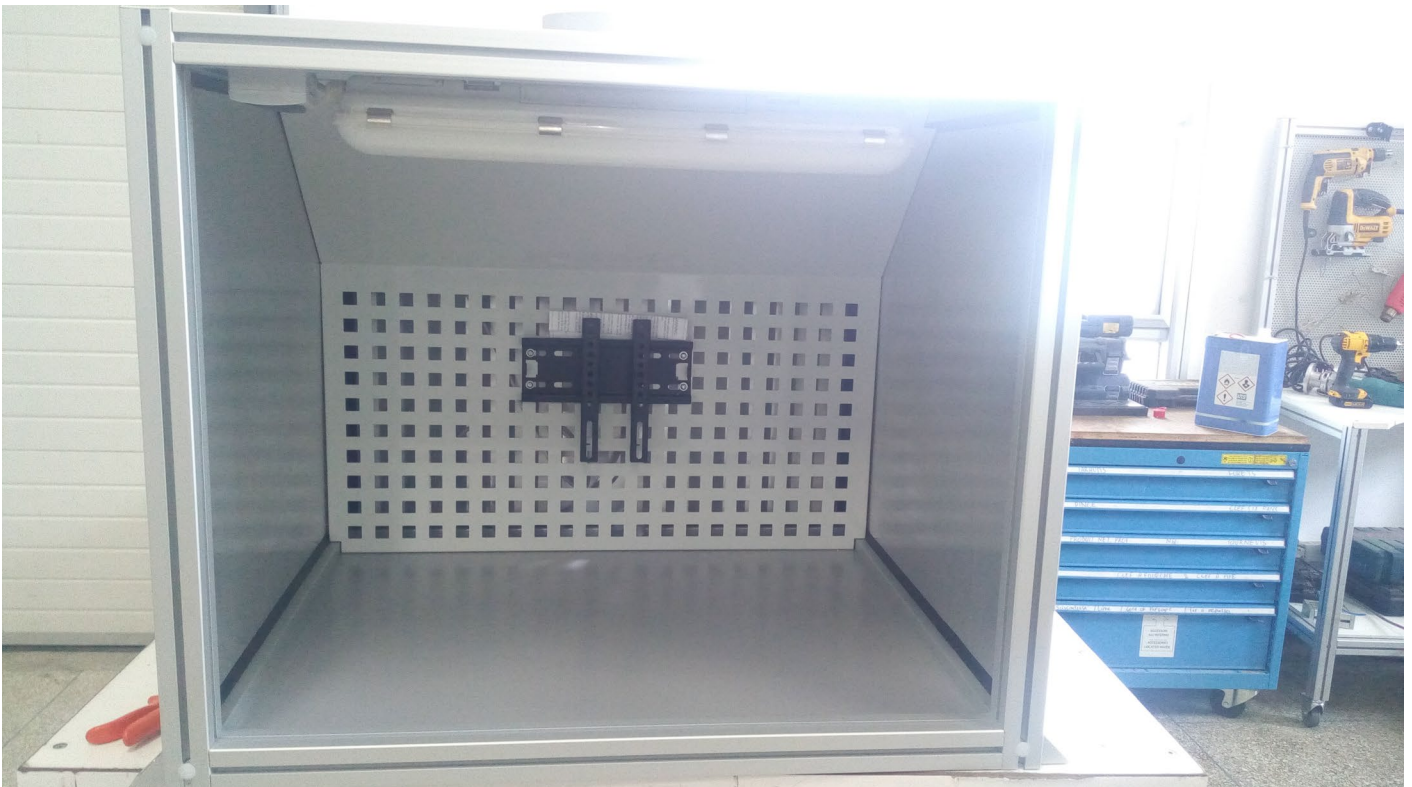
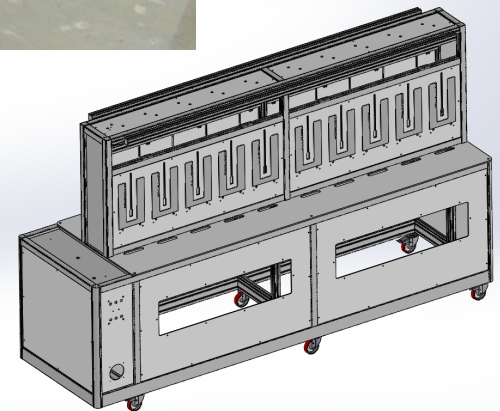

Norcan Morocco -  
PST mix



Norcan Morocco -  
Pactibox storage



Norcan Morocco -  
Frame for riveting



Norcan Sverige - Pinching conveyor to transport bottles through a labelling device



Norcan Sverige - Machine guarding with folding doors



Norcan Sverige  
Cryogenic cabinet for safe filling  
of liquid nitrogen bottles



Norcan Sverige - Sphere with  
cameras for 3D  
modeling of people and objects



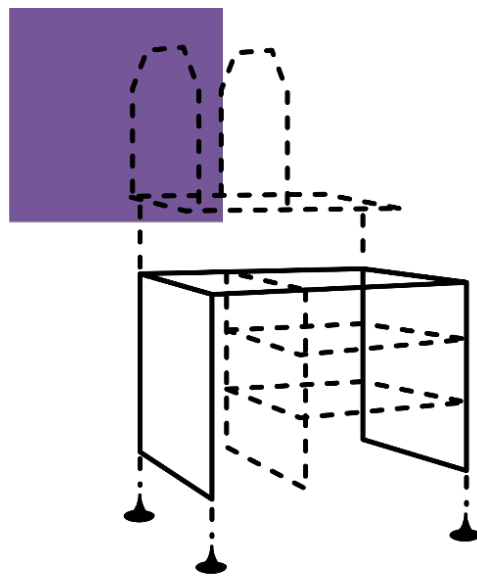

Workstations and  
technical furniture

**EC20V00157-AA**

PR2008118 – RNA/VBE  
Workstations

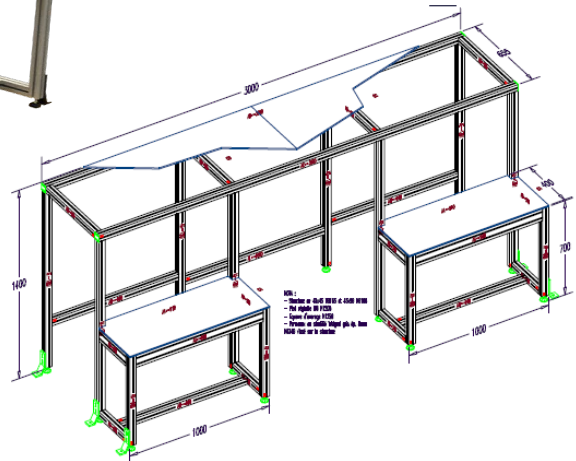

PR2009533 – HRO/CHS  
Dismantling stations for spraying systems



PR2008904 – RNA/NCA  
Workstations

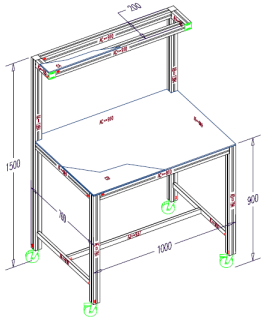

**EC20X00491**

PR1901562 - CLI  
Tool holder

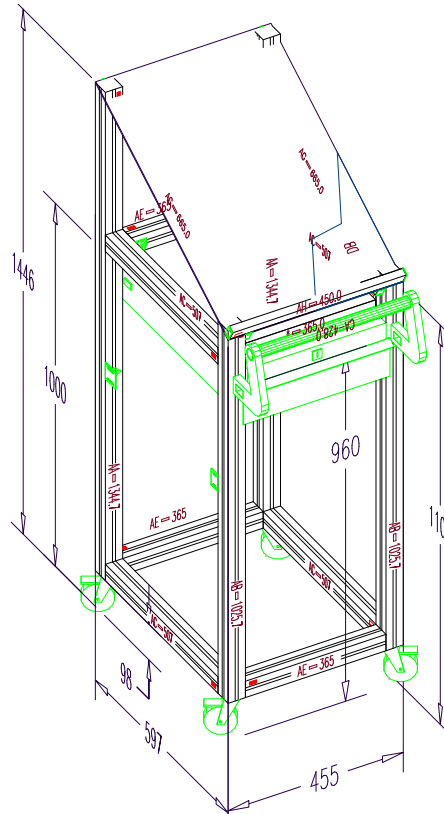

EC18W00394

PR2005522 - CLI/NDO  
Table with rollers

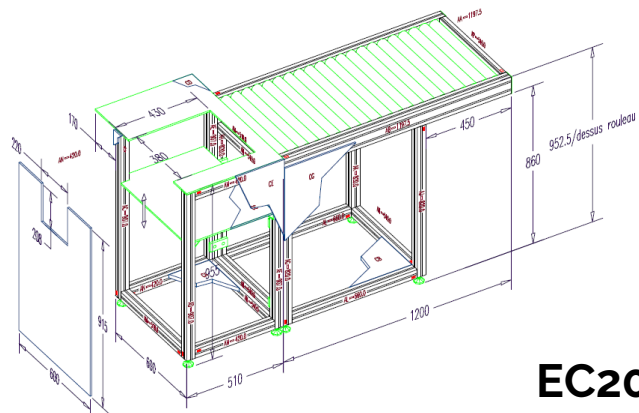

EC20A00090

PR2000397 – Norcan GmbH  
Desk with manual height adjustment

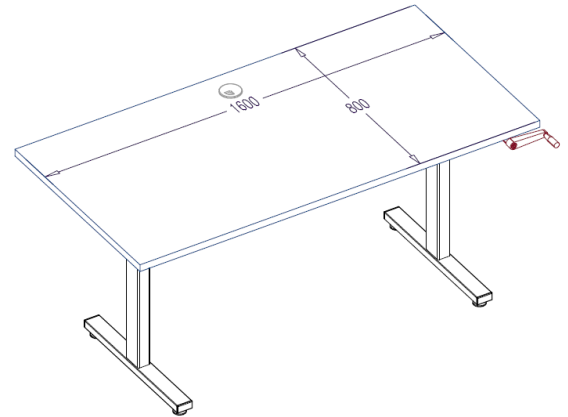

**EC19L0067**

PR2008777 – Norcan GmbH  
Workstation



**EC20W00104**

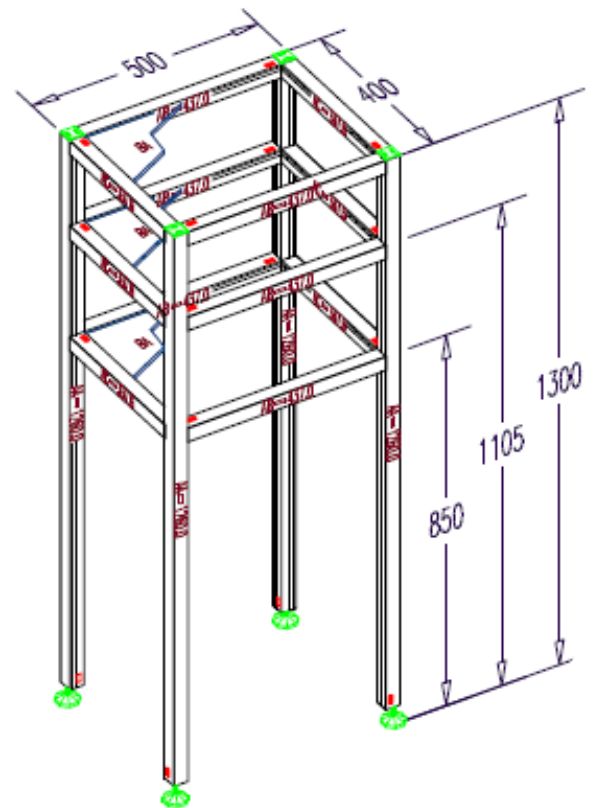





PR2001715 – SEP/PFJ  
 Desk for checking incoming packages +  
 sideboard

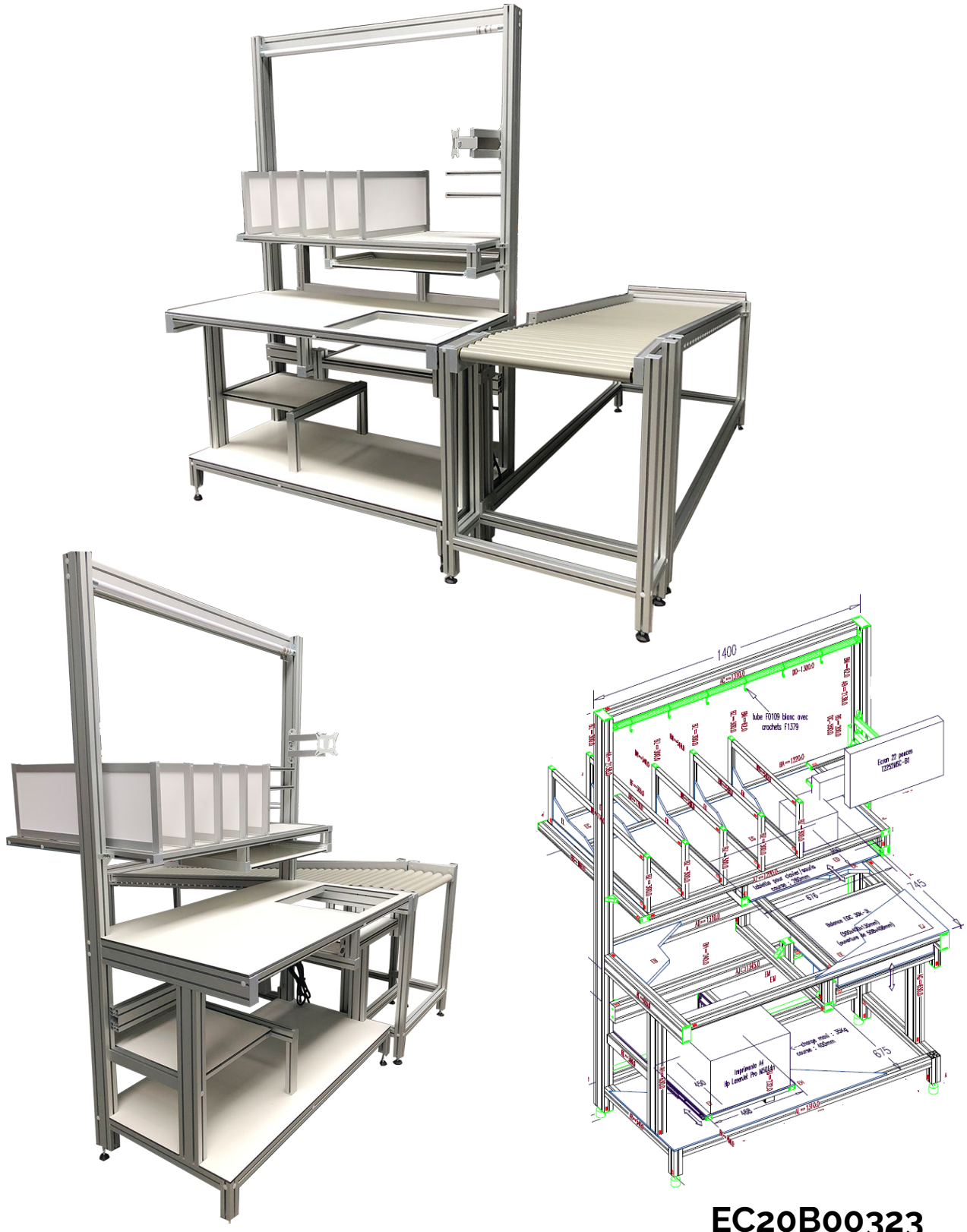

**EC20B00323**

PR2008107 – RNA/WEC  
Packing workstation

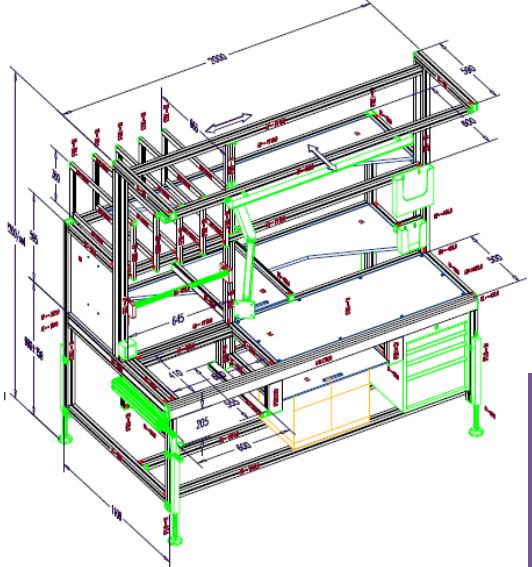

**EC20X00057**

PR2008620 – Norcan GmbH  
Packing station – face to face

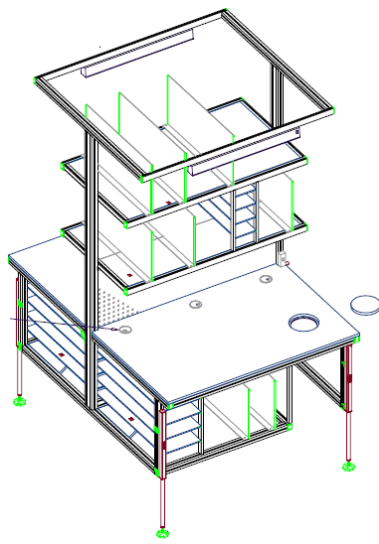

**EC20L00165-AC  
EC20L00210-AE**

PR2007285 – Norcan GmbH  
Mounting bay - 2 integrated scales -  
conveyor system for evacuation

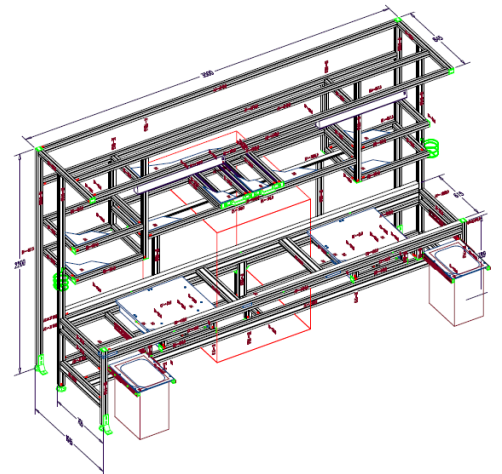

**EC20T00133-AA**  
**EC20T00309-AB**

PR2008899 – Norcan GmbH  
Mobile workstation with lift/lower and battery

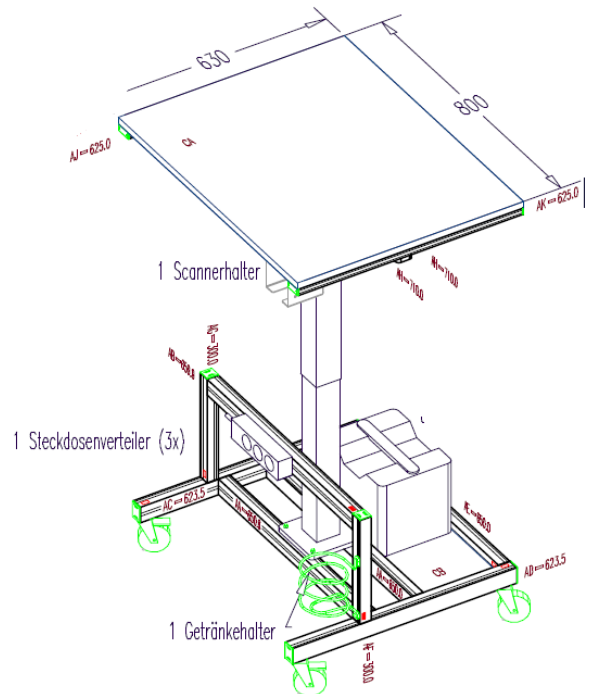

**EC18T00337-AD**

PR2003679 – Norcan GmbH  
Packing station



**EC20C00119**

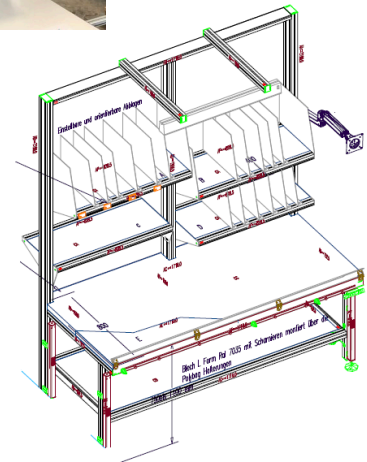

PR2007589 – RNA/CHS  
Packing table - stainless steel - aluminium frame - smooth face profiles - for the food sector

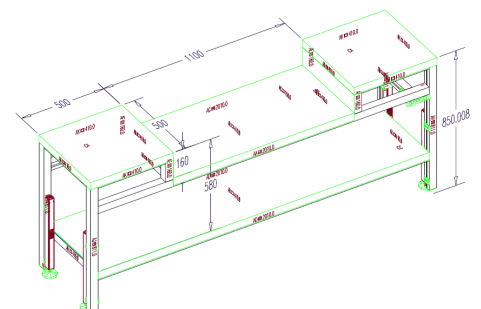

**EC20W00117-AB**



PR2005466 – FLA/LBE  
 Workstation - returns processing  
 Up and down system



**EC20V00247-AA**

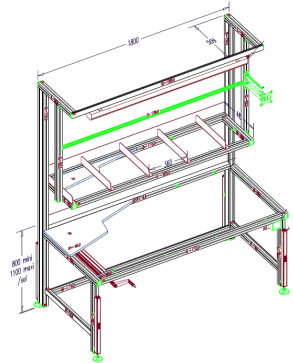

PR2007849 – HSC/VBE  
 Mobile station with stainless steel tray



**EC20W00116**

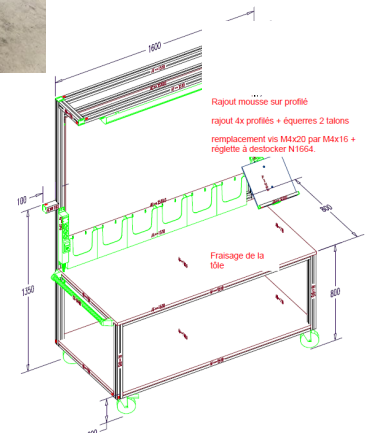

PR2006175 - Norcan GmbH / Double position  
up and down system with electric columns  
labeler integration - evacuation column

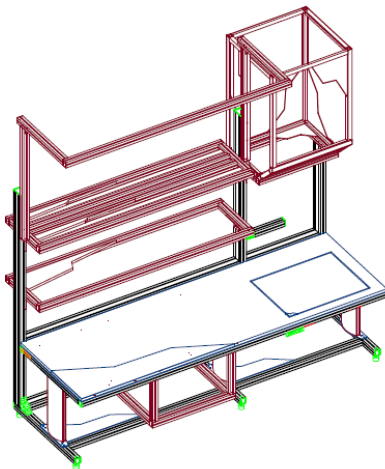

**EC20T00388/386/384/379/333/330  
/332/320/311/310/307/304/302**

MN16554 – Norcan Hispanica  
 Multipurpose table with 2 working boards.  
 Panels in stainless steel.

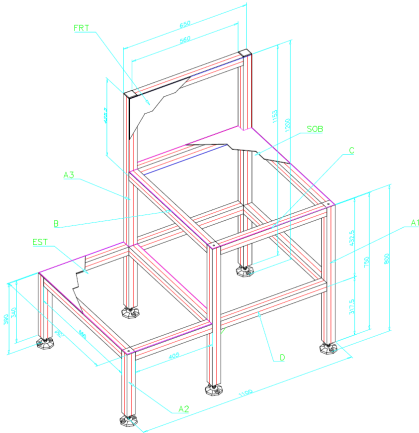

MN16502 – Norcan Hispanica  
 Folding table for a convenient  
 storage when it is not used.  
 Simple unfolding system, top  
 surface in stainless steel

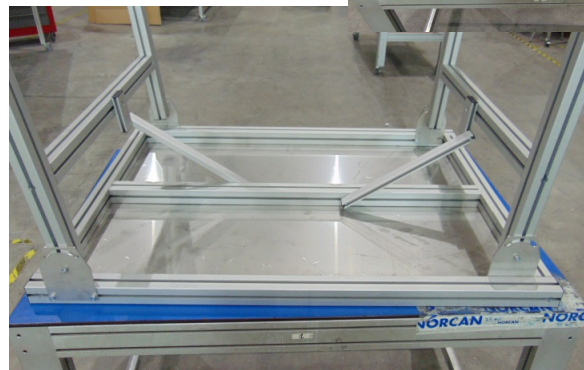

MN16897 – Norcan Hispanica  
 Workstation for an efficient assembly of electrical cabinets, Adjustable  
 board for different sizes of cabinets. Holder for a sticker printer and  
 sorting tray for big cabinets on the left side. Front panel in coated steel  
 to attach the instructions with magnets. Bottle holder, footstool,  
 lighting system.

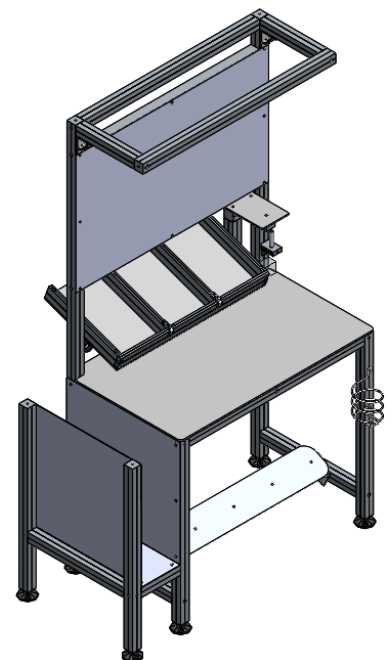



## Norcan Maroc - Cutting table



Norcan Morocco -  
Control station for hydraulic  
circuits of cars With an extension  
board for long sheaths

Norcan Morocco -  
Double sided control station for  
two technicians facing each other







PR2008914 – Norcan GmbH  
Provisioning station



**EC19B00046**

PR2008394 – RNA/VBE  
Provisioning station

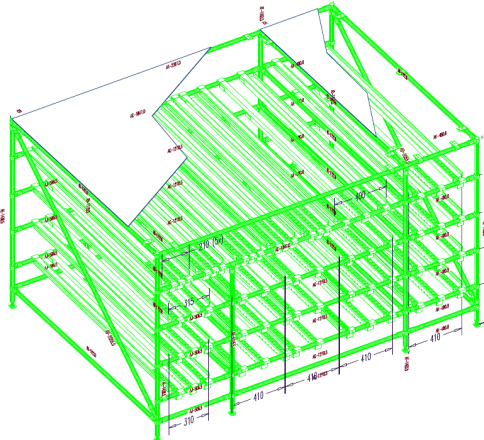

**EC20W00241-AB**

PR1912239 – MGR/LOM  
Station for the assembly of fragile objects

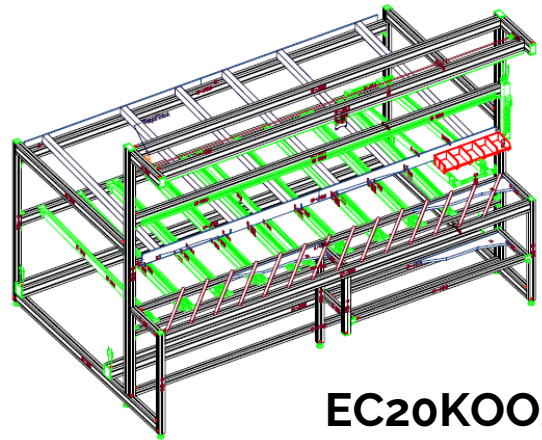

**EC20K00219**

PR2007576 – CLI/NDO



**EC20N00225**

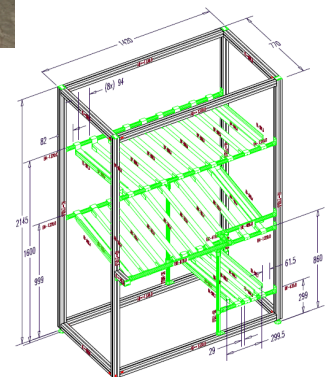

PR2005526 – Norcan GmbH  
End of line station  
Integration of ramps that bring the bins

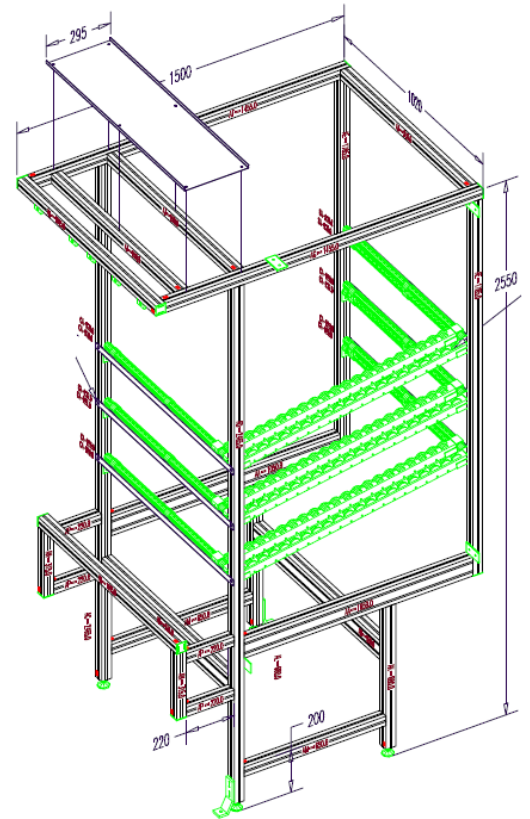

**EC19B00059-AG**

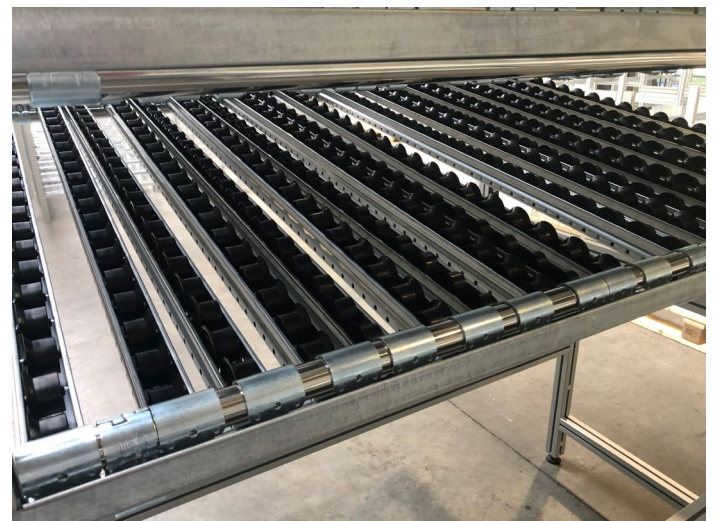

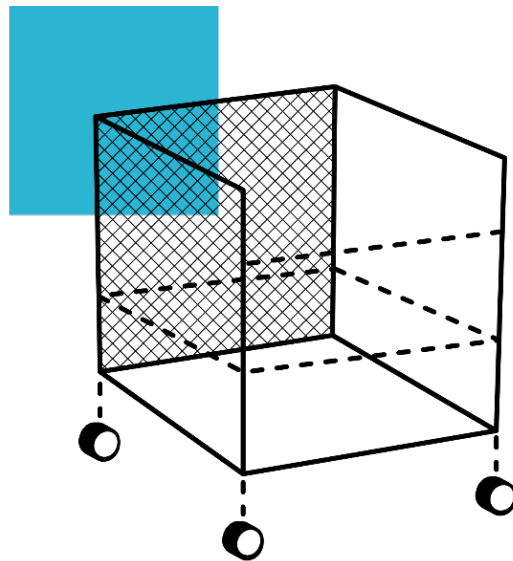

Trolleys & carts,  
material handling

PR2002768 – RNA/LOM  
Trolley to prepare kits – vertical storage

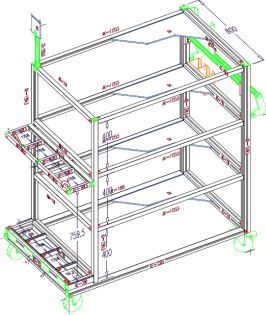

**EC20W00278-AE**

PR2000129 – HSC/CHS  
End of line trolley

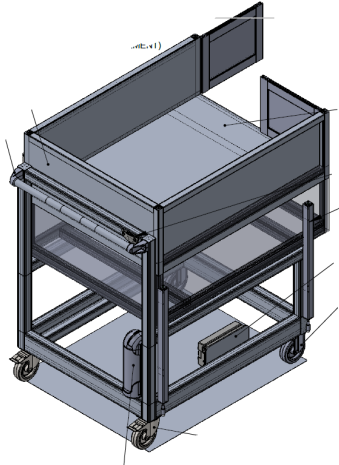
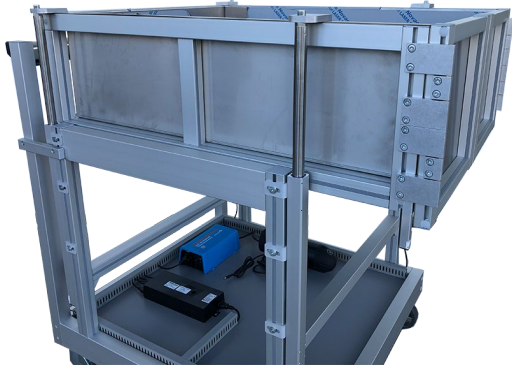

**EC2020102**



PR2004818 – CLI/CHS  
Rotative frame for presence sensor



**EC20C00220**

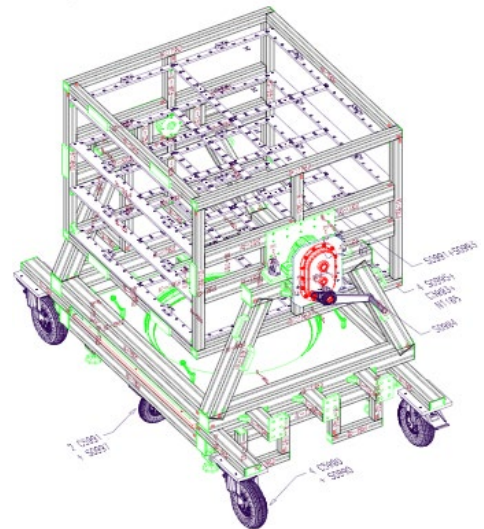

PR2004736 – SEP/CHS  
Trolley for a university

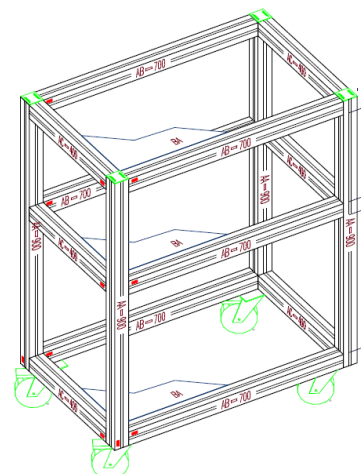

**EC20U00167-AA**  
**EC20U00163-AA**  
**EC20U00284-AA**

PR2004548 – HSC/NDO - H175 trolley with 5 drawers for an assembly line



**EC18Y00004**

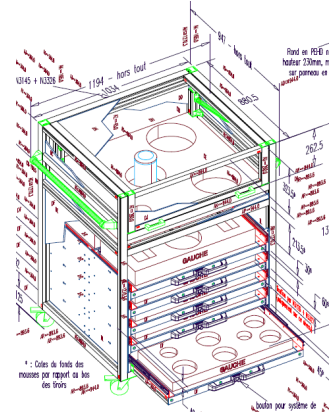

PR1910337 – MGR/VJU Support trolley

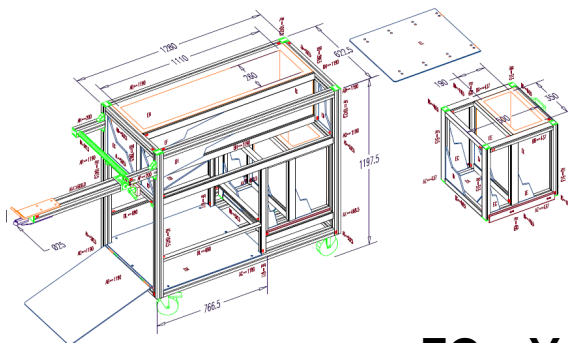

**EC19Y00098-AB**

PR2002760 – Norcan GmbH  
Rebin XL trolleys



**EC19A00078-AE**  
**PC17R00327-AA**

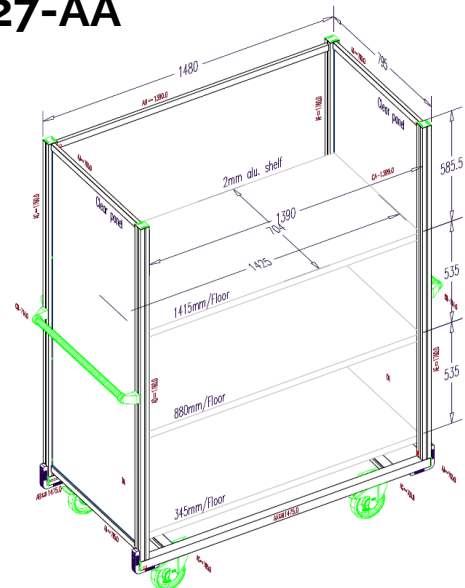

PR2008826 – CLI/LOM  
Standard Rebin trolleys

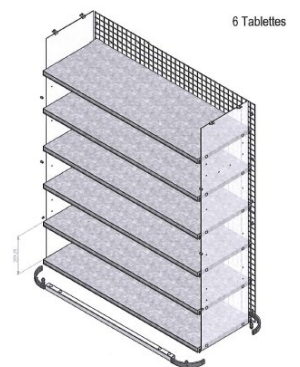

**EC20W00115**

PR1911814 – LDB/ZES - Trolley to prepare kits with integrated footstool

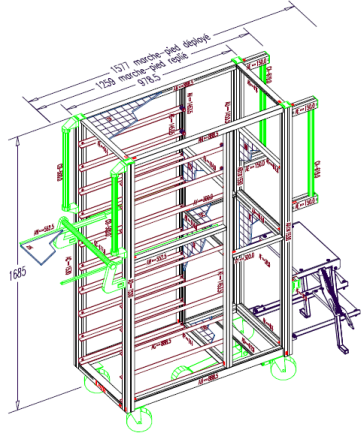

**EC19D00115**

PR2007895 – CHW/TZO

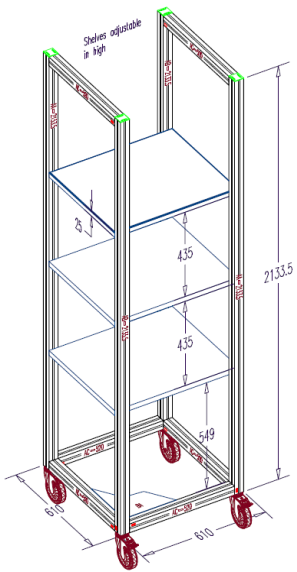

**EC17T00166-AB**

PR2004971 – Norcan GmbH  
Cart for tool transport



**EC20J00144-AD**

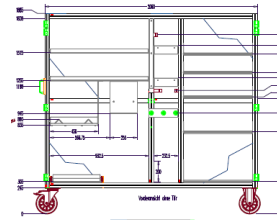
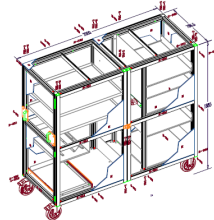

PR2003833 – XPAG/LBE  
Test stand trolley



**EC20U00330-AA/EC20U00331-AA**

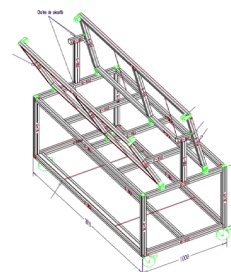

PR2001299 – MGR/VBE  
transport cart with compartments and  
retractable shelf

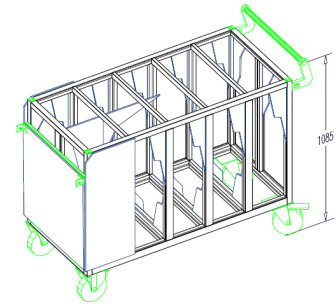

**EC20T00395-AB**

PR1913104 – HRO/ZES  
Cart for storage of leather goods skins

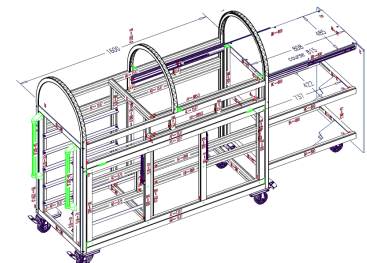

**EC20G00172**



PR1911175 – HRO/NKO  
 Tool storage cart for  
 manufacture of electronic cards

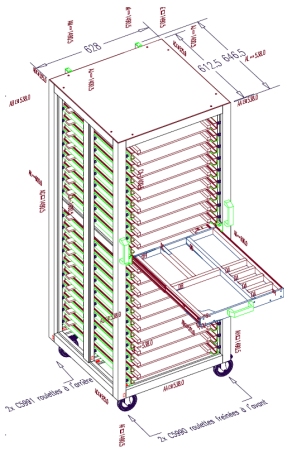

**EC19U00358**

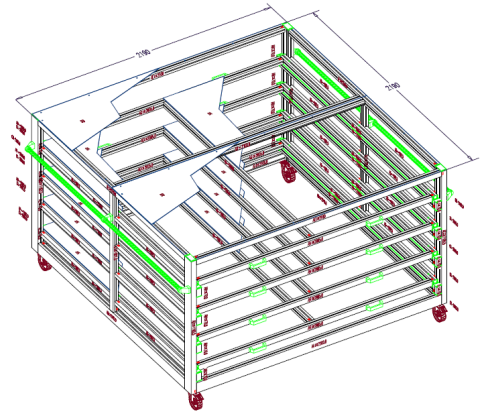

PR2004840 – HSC/WEC  
 Chariot 2100 x 2100 mm

**EC20T00399**

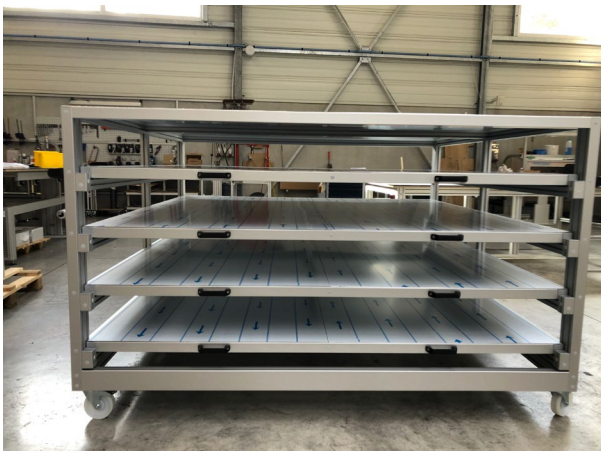



PR2003554 – Norcan GmbH  
Picking cart for transport of box

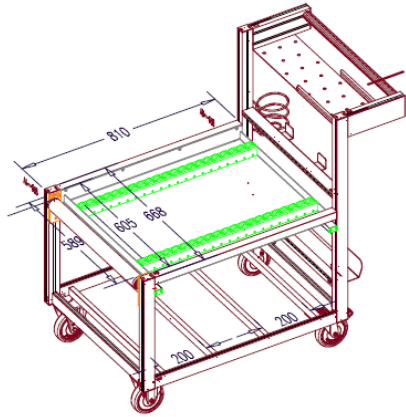

**EC20M00047-AB**

PR2003901 – HRO/VBI  
Customizable end of line trolley

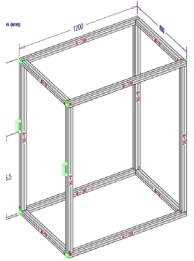

**EC20M00005**

PR2001302- LDB/LOM  
Presort trolley

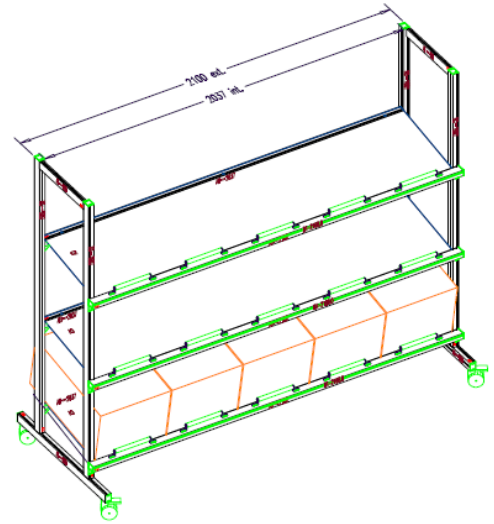

**EC18J00243**

PR2003430 - WEC

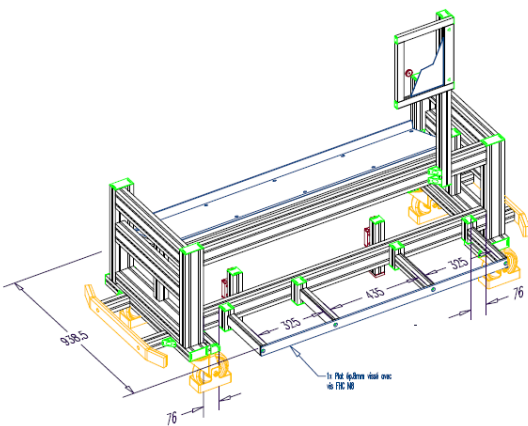

**EC20M00118**

# Norcan Maroc - Handling trolley



# Norcan Maroc - Trolley



Norcan Morocco – Trolley to transport parts coming out of the oven at 180 °C  
Board in laminated panel



Norcan Morocco -  
Trolley to carry rollers ; to unwind composite rollers  
In front of the cutting station



Norcan Morocco -  
Transfer trolley :  
Transports composite feet  
at the exit of the oven

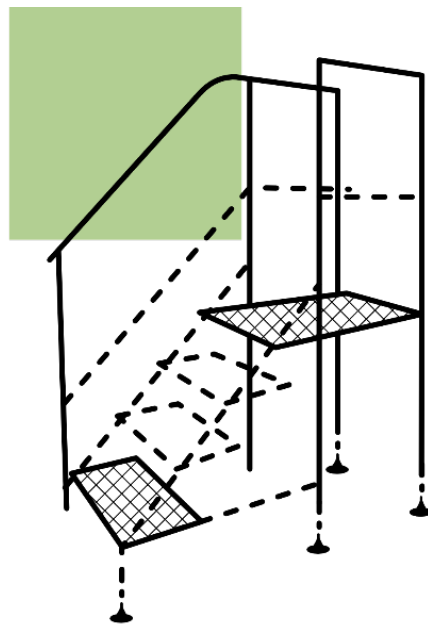

Access platforms,  
gangways and steps

PR2000182/89 – HRO/VBE  
Platform and rolling staircase

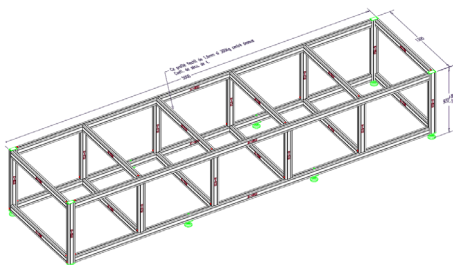

**EC20A00381**

PR2007157 – MGR/WEC  
Catwalk staircase

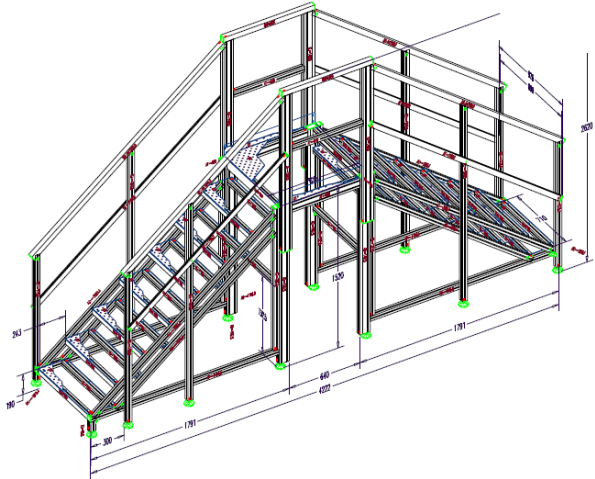

**EC20V00153-AD**

Norcan Morocco  
Platforms



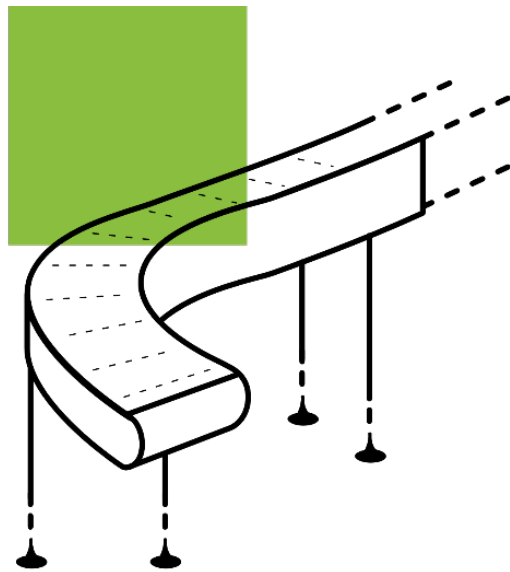

Material flows  
and conveyors



PR1908536 – LDB/QNI - Toothed belt conveyor with attached profiles



- EC19Y00345-AD**
- EC19Y00346-AC**
- EC19Y00344-AC**
- EC19Y00347-AB**

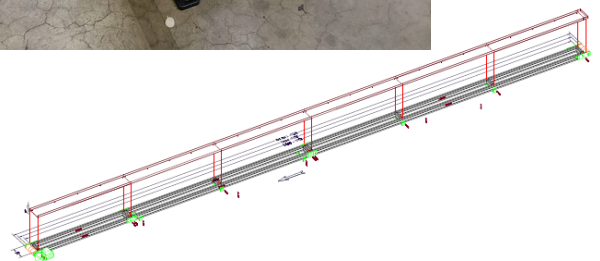

PR1908791 – RNA/NIS  
 Conveyor at the exit of a bobbin

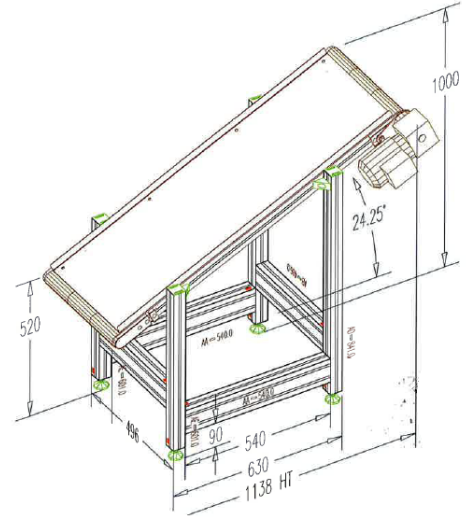

**EC20A00100**

PR2005934 – SMR/BME  
 Loading conveyor and gravity conveyor

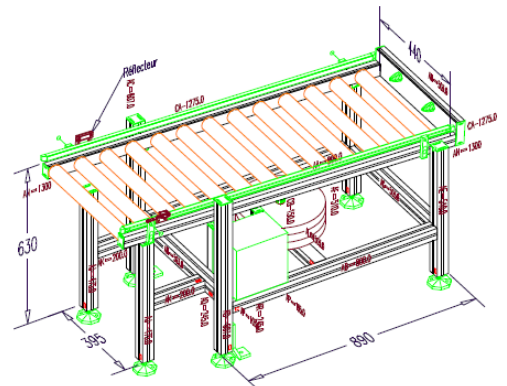

**EC20Q00027/28/30/40**

PR2007405 – SEP/ZES  
Incoming goods station with conveyor  
Module for orders routing

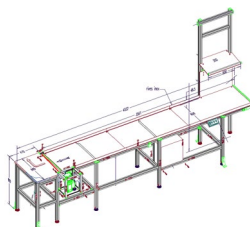
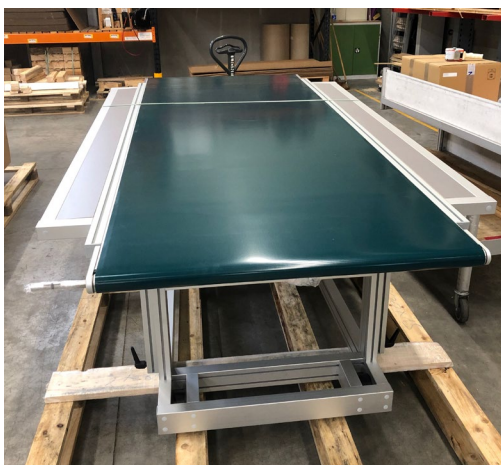

**EC16V00287-AB**

**EC20N00053/59/60/41/110**

PR2002130 – PAG/PRB  
Conveyor with a diameter of 50



**EC20N00053-AC/EC20N00059-AD/EC20N00041-AC**

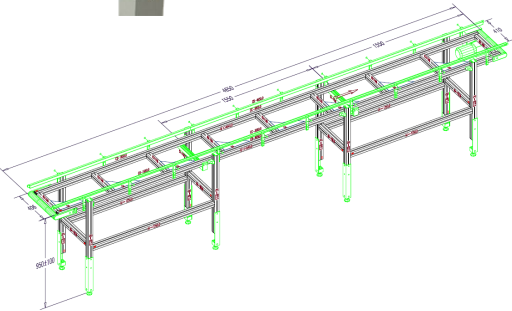

PR2006246 – Norcan GmbH  
Modular conveyors

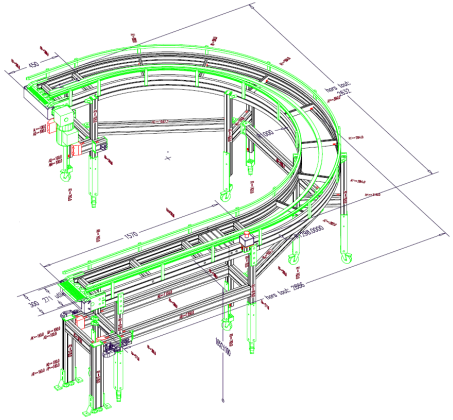

**EX20W00076-77-78-79-80-81**

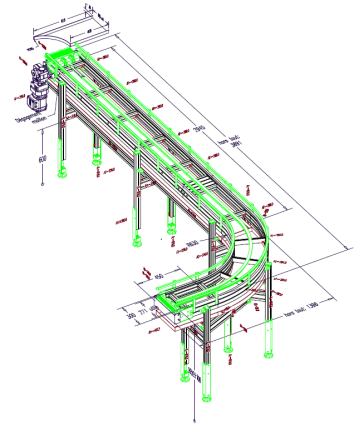



PR2007534 – Norcan GmbH  
Curved conveyor

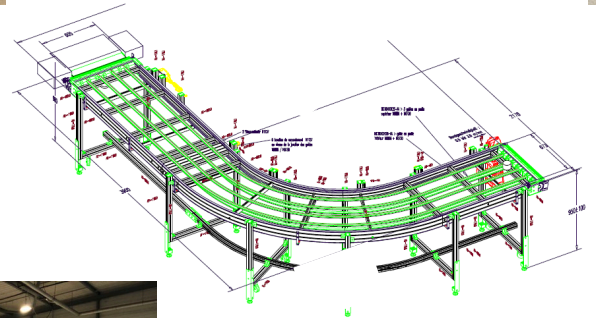
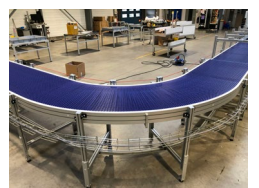

**EC20W00106-AA**

PR2006009 – RNA/NIS  
2 conveyors on wheels

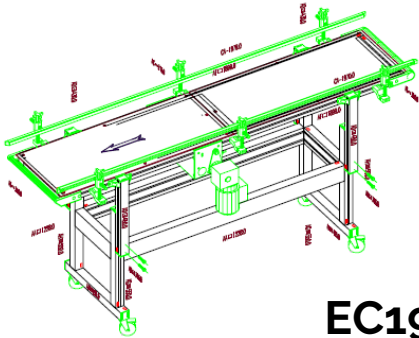

**EC19X00149**

PR1911250 – HRO/CLL  
Conveyor for robotics

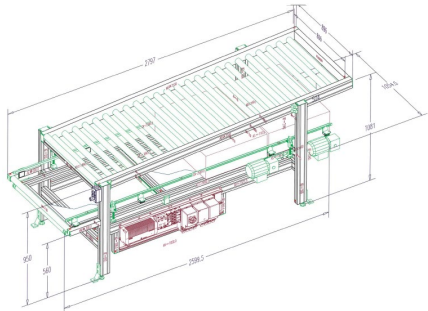

**EC19X00149**







PR2006378 – Norcan GmbH  
Storage unit for workstation  
automatic feeding - free rollers

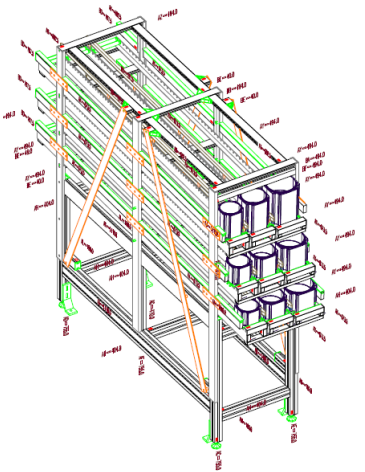

**EC20S00096-AD**

PR2003808 - MGR/CLL  
Gravity conveyor

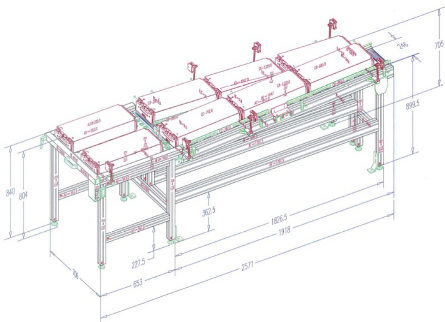

**EC20D00399**

PR1902521 – Norcan GmbH - Packing workstation - free roller conveyor at the exit - integrated lift

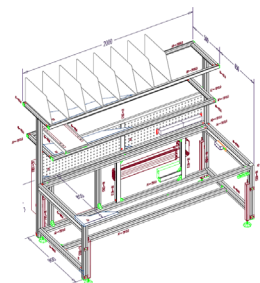

- EC19F00018-AE**
- EC19V00182-AA**
- EC19K00161-AB**
- EC19W00255-AB**
- EC19V00240-AD**

PR1908572 – MGR/CLL  
Roller chain conveyors



- EC20D00198-AA
- EC20D00199-AA
- EC20D00200-AA
- EC20D00201-AA
- EC20D00188-AA
- EC20D00458
- MC20D00187

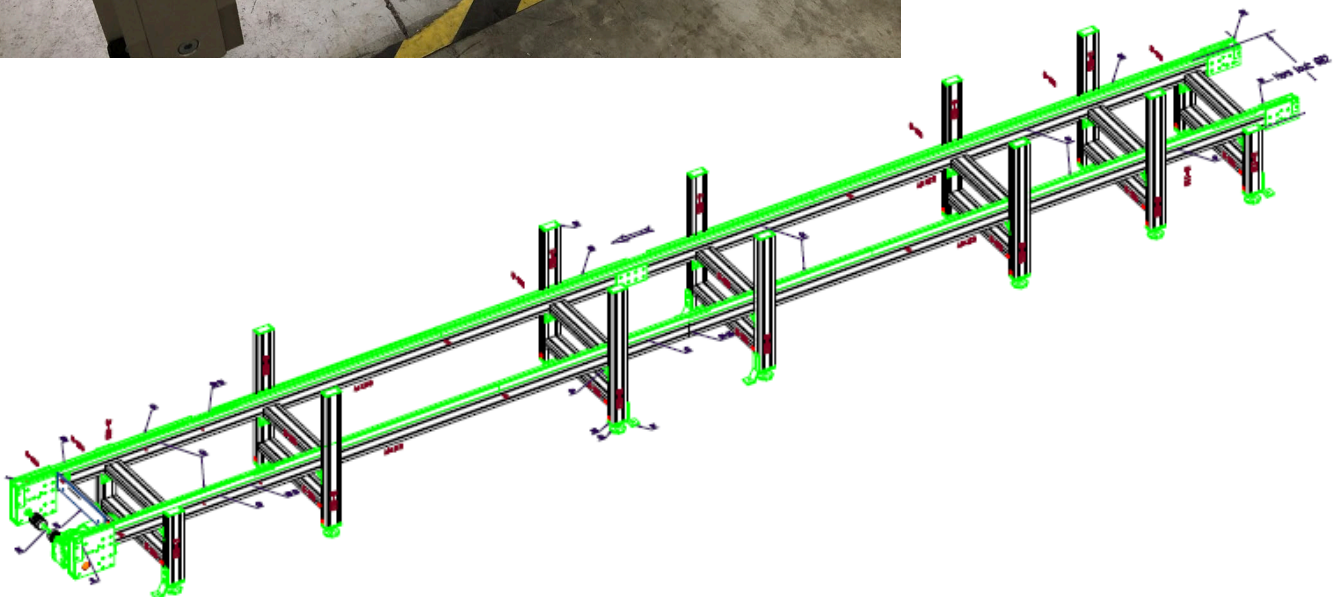

MN16066 – Norcan Hispanica –  
Packaging line for veterinary drugs–  
10 different formats. Table with a central  
conveyor for the packing, Conveyor with a manual  
bypass to feed two lines of labelling  
machines. Placed in a white room with  
closed profiles and boards in stainless steel

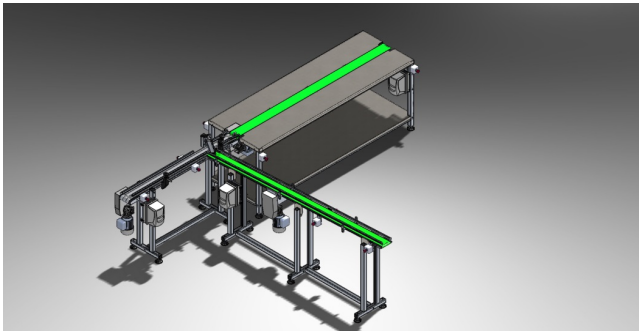

MN16235 – Norcan Hispanica – Special conveyor with suction system for 4 different areas. Group of 5 conveyors with central motorisation for the manufacturing of medical bandages of different sizes, Several operations are conducted in the various sections of the machine: straightening matrix, feeding of adhesive film, feeding of packing wrap, expulsion of the finished product. The suction system is meant to keep the tissue flat during the whole

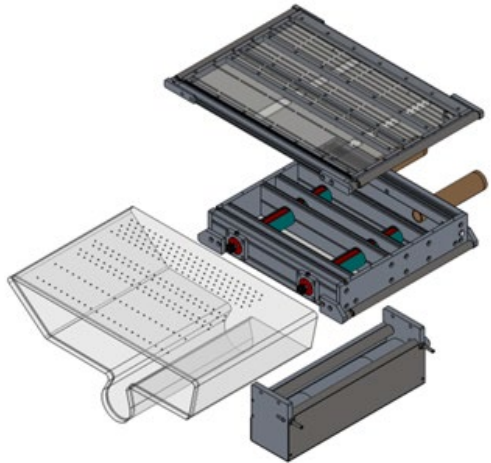

MN16694 – Norcan Hispanica – System for the filling of individual boxes (Ketchup - Mayonnaise - Mustard ...), Empty boxes brought by a conveyor with cleats, filling station with tilted conveyor and vibration system to equalize the volume of sticks in the box, filled box ejected with a dynamic rail conveyor made from N0868 and N1634

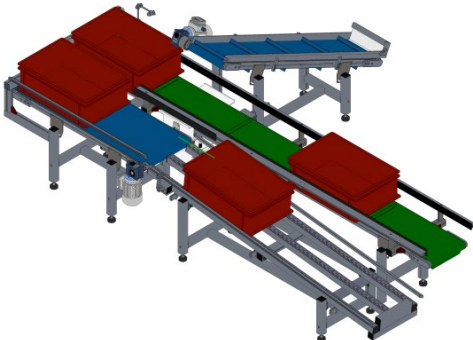

MN16880 – Norcan Hispanica - Conveyor ø95 with 1 inflection point, Transports moist clay lumps between the dosing machine and the press. Belt with corrugated sides Bordoflex. For ceramic tiles



Hispanica  
**NORCAN**

MN16918 – Norcan Hispanica  
Line for the transport of electronic materials for air-conditioning systems. Gravity ESD rails and motorized ESD rails

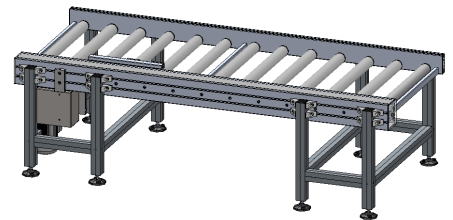

MN16418 – Norcan Hispanica – Line for the transport of car parts. These Ø95 conveyors are equipped with wheels and guides to combine them based on the transported parts and the unloading direction for the next operation



MN16823 - Norcan Hispanica – conveyor at the exit of a machine with a fallproof stop. Ø50 conveyor with an inflection point. Specific measurements: c = 716 mm b = 700 mm and length = 4500 mm with 2 guides





Norcan Morocco -  
Conveyor of car windshields and door panels  
- height adjustable with actuators



Norcan Morocco



Norcan Morocco





Norcan Morocco  
Hybrid conveyor



# Norcan Sverige - Conveyor for the assembly and transport of syringes

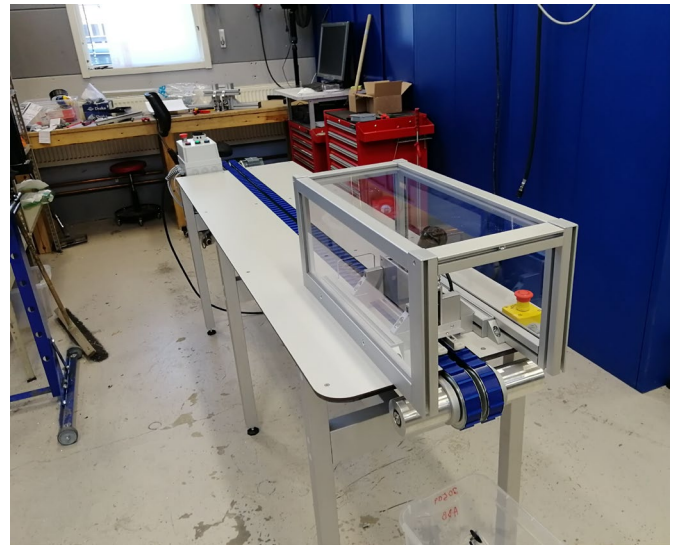
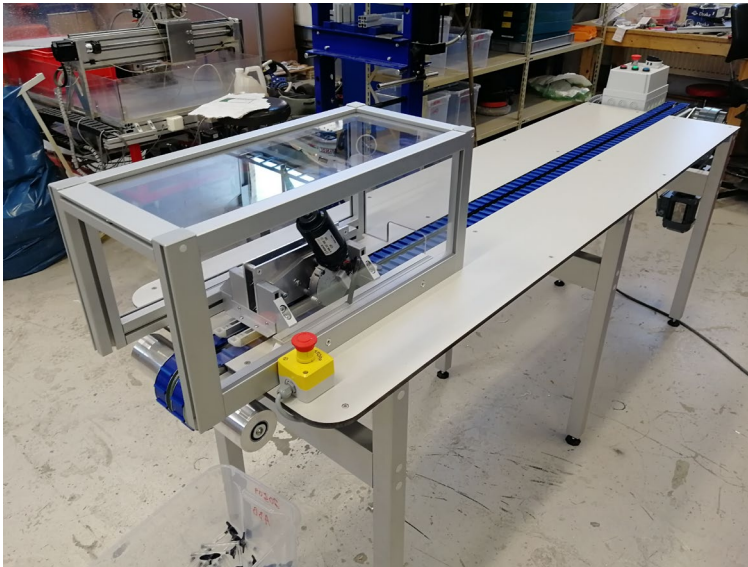

# Norcan Sverige - Machine to cover books with plastic foil



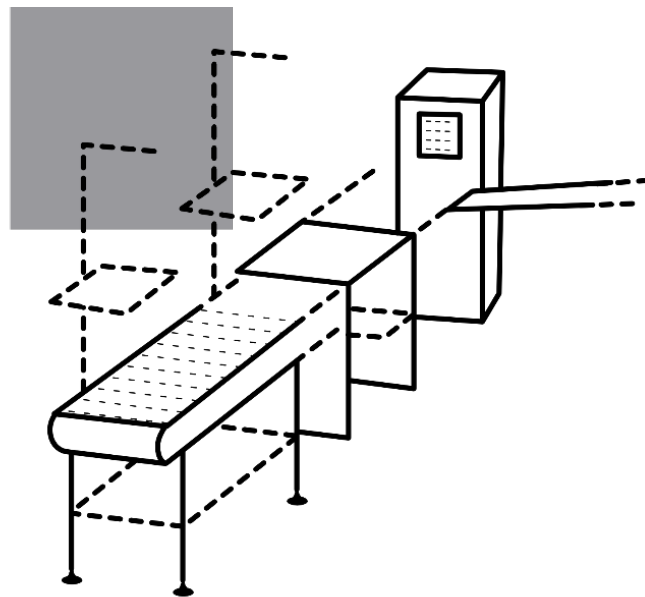

... specialized  
production cells  
and full installations

PR1908143 – PAS/EKE  
 Conveyor with a hub station

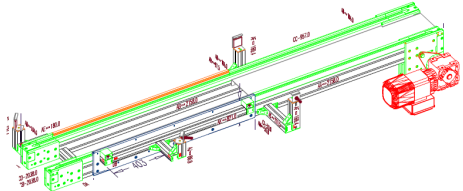

**EC19U00021-AD/EC19U00151-AD/EC19U00183-AD**

PR1906882- MGR/QNI  
 Bi-band elevator

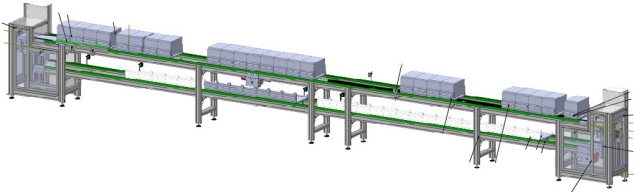

**EC20D00200/186/187/201/149/150/370/248/371/292/316  
 /042/123/368/369/373/141/152/133/168/294/299/078**

PR2007529 – Norcan GmbH  
Double packing station



**EC20U00050-AA**  
**EC20U00065**  
**EC20U00089-AA**

PR2005764 – SEP/PFJ  
Handling line  
with zero pressure accumulation system

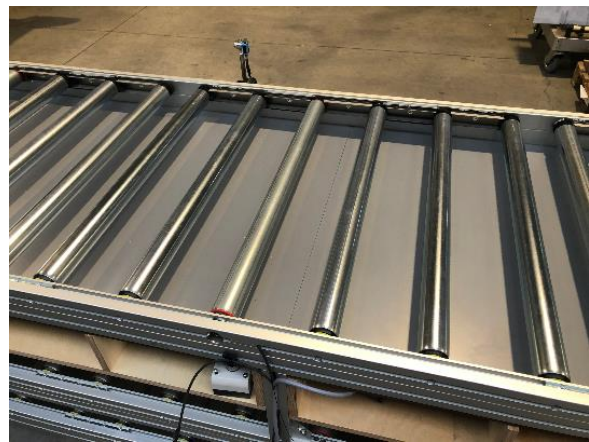

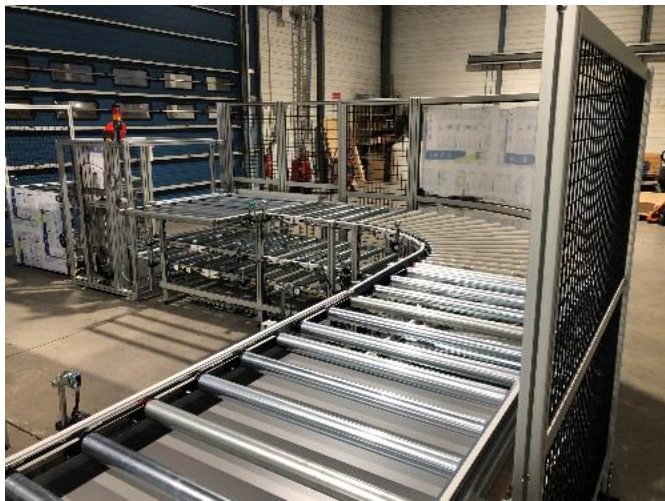





**EC20T00191/208/193/200/201/203/197/198/1  
94/199/207/196/202/205/209/206/190**

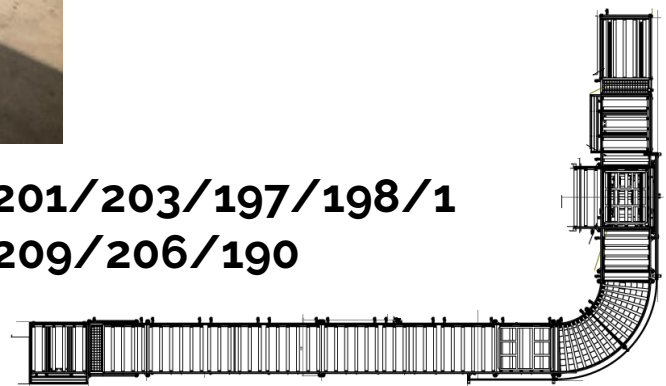

PR2007361 – RNA/VJU -Conveyor with zero pressure accumulation system



**EC20X00200/203/204/205/206/208/209/197**

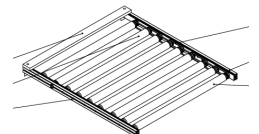

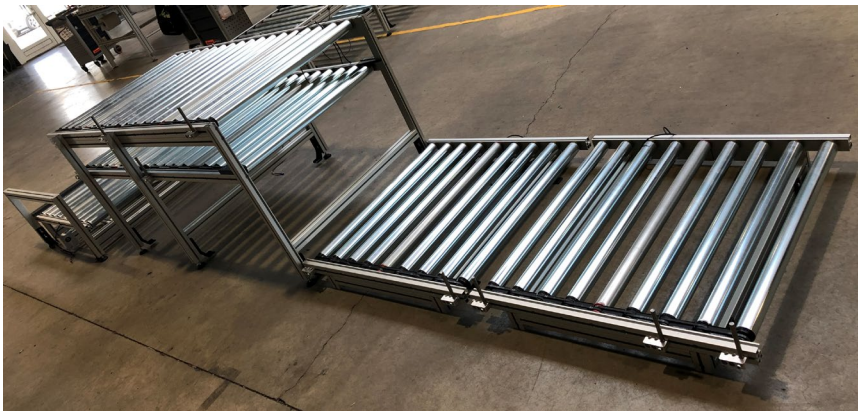

**NORCAN**  
48 rue des Aviateurs  
67503 - Haguenau  
+ 33 3 88 93 26 26  
info@mynorcan.com

